

WING WALL CROSS SECTION
Scale 1:25

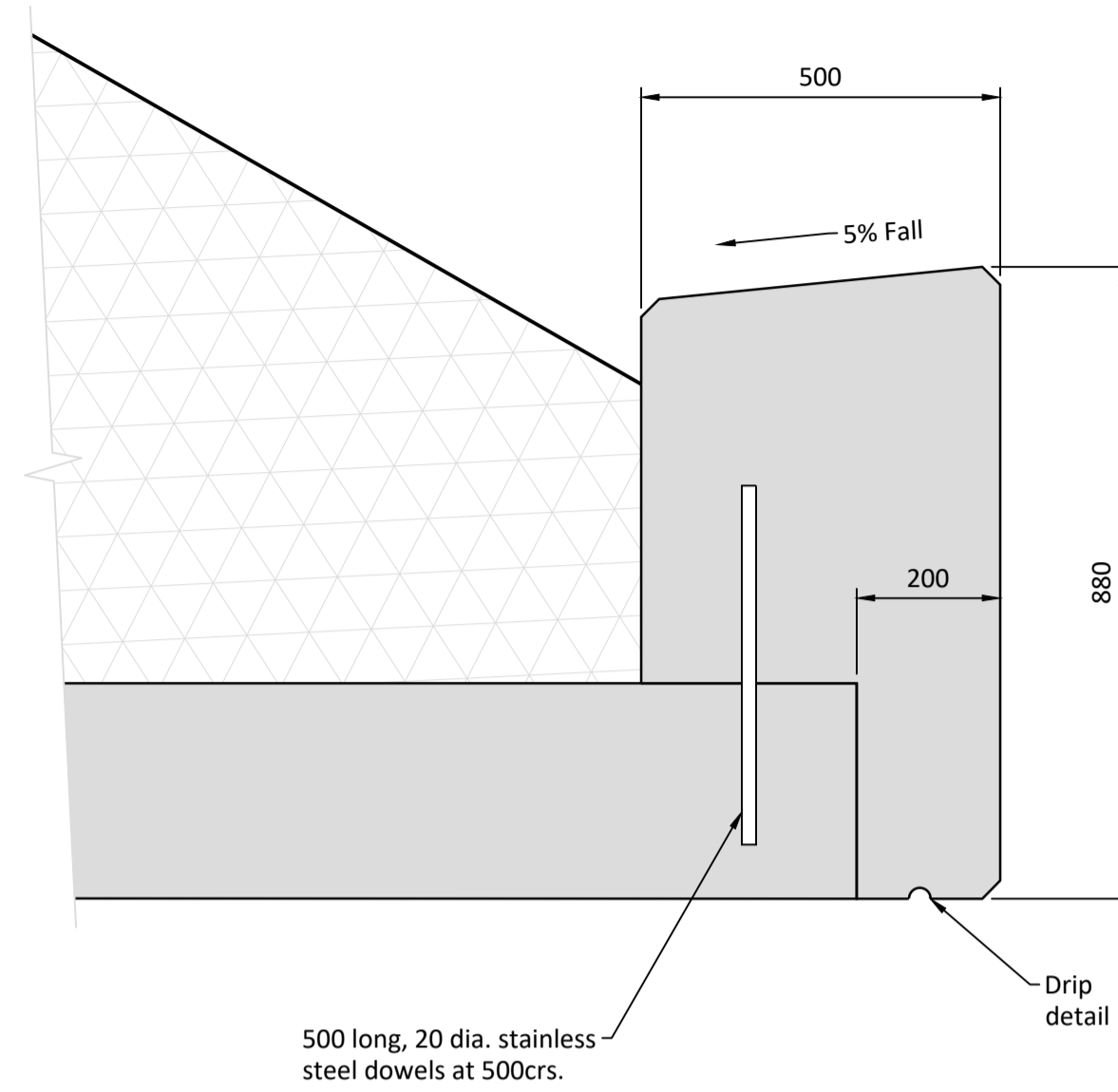

HEADWALL DETAIL
Scale 1:10

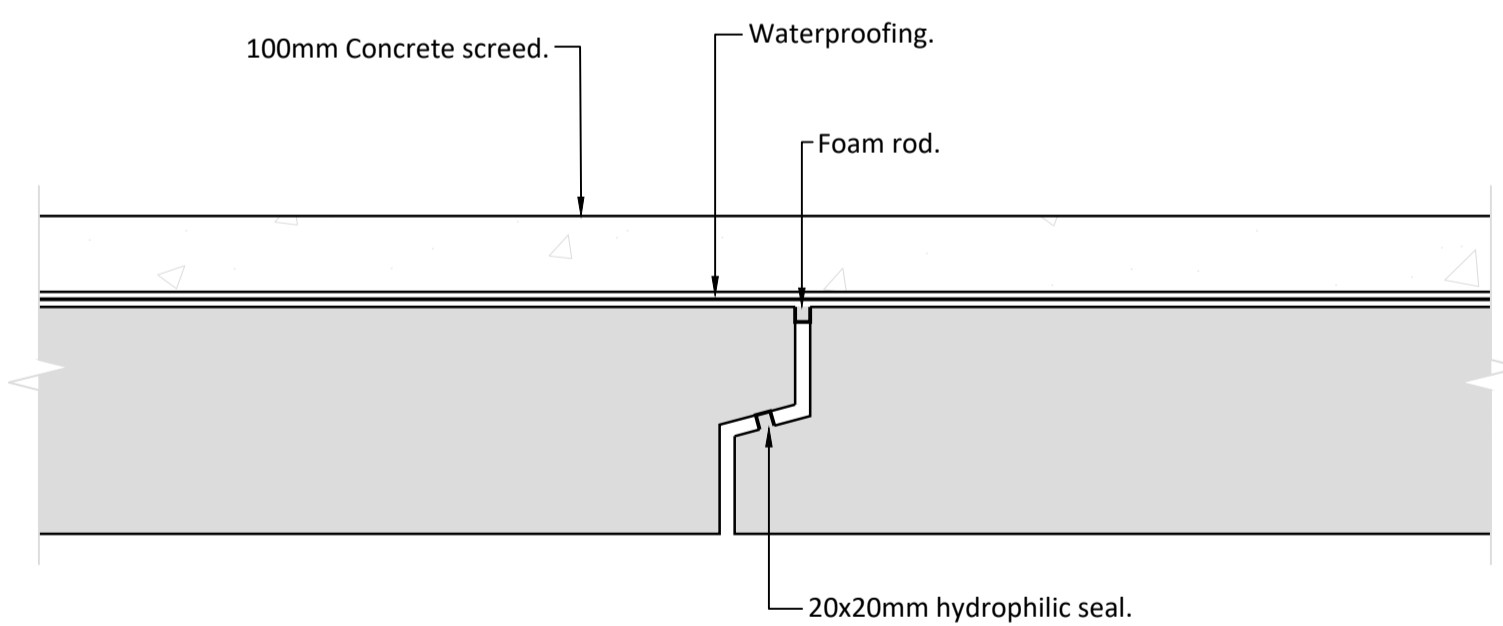

BASE JOINT DETAIL
Scale 1:10

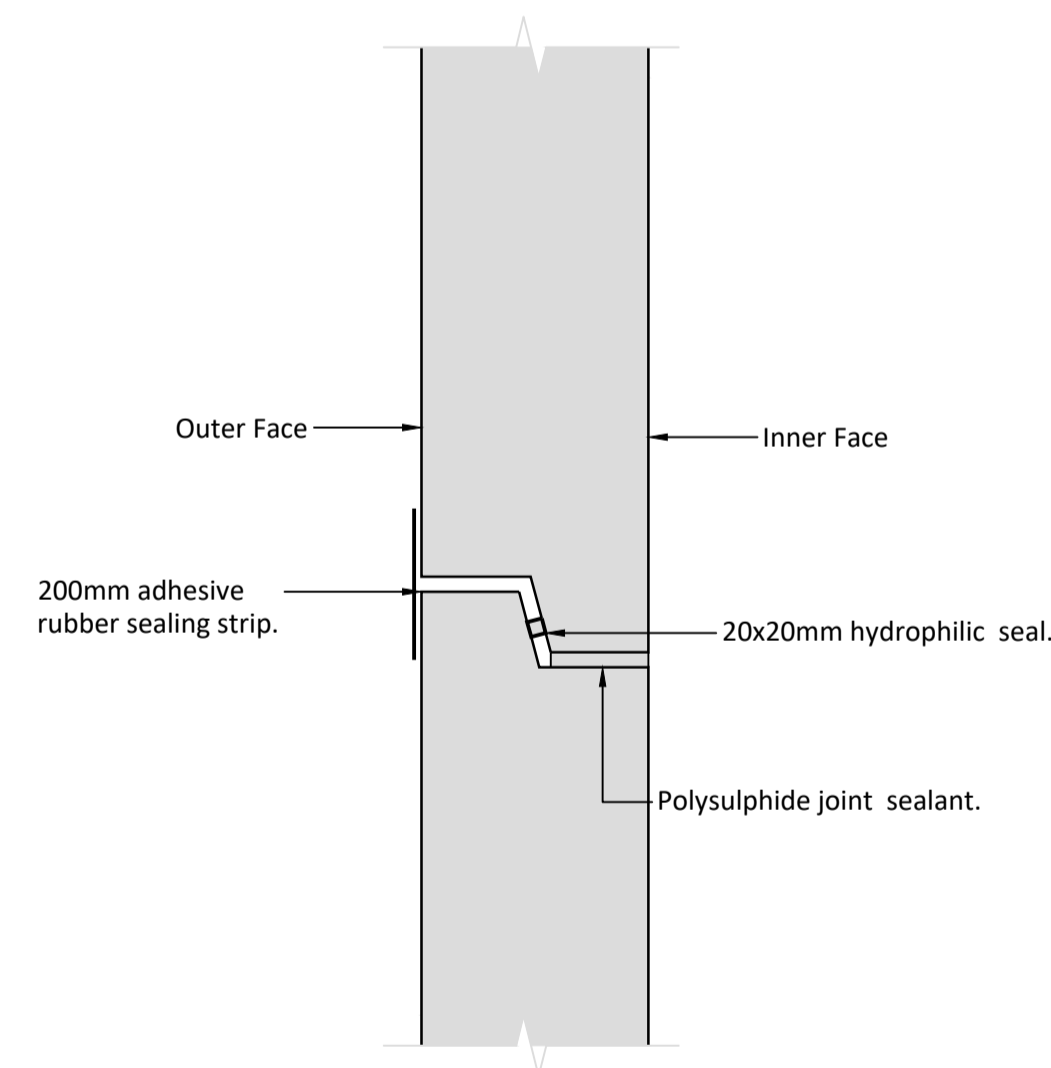

WALL JOINT DETAIL
Scale 1:10

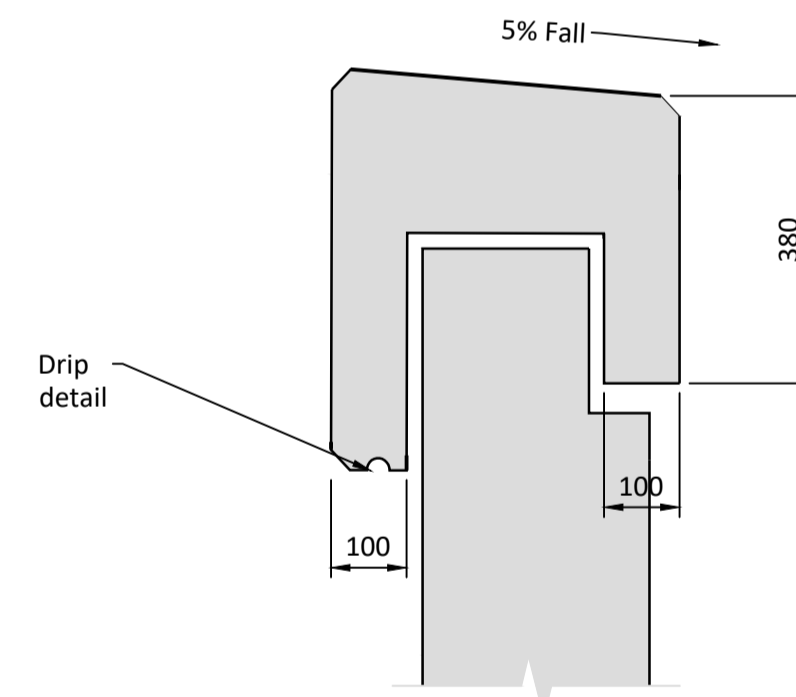

WALL COPING DETAIL
Scale 1:10

- NOTES:**
- This drawing should only be read in relation to subject of the Title. Other information shown on drawing is to be considered indicative only. Reference should be made to appropriate drawing series for other information.
 - All dimensions are shown in millimeters unless noted otherwise.
 - All levels are shown in meters above ordnance datum.
 - Concrete finish to be as follows:
Buried unformed surfaces: U1
Exposed unformed surfaces: U3
(excluding areas to receive waterproofing)
Buried surfaces: F1
Exposed surfaces: F4
Area of deck to be waterproofed: U4
Headwall / Wall coping: F3/U3
 - Materials:
Precast Concrete Box: Grade C40/50/GGBS
Precast Concrete Walls: Grade C40/50/GGBS
Precast Concrete Headwalls: Grade C40/50/GGBS
In situ Concrete Foundation: Grade C40/50
Concrete for Blinding: Grade ST1
 - 6N/6P Structural backfill to be selected to have σ' peak between 35° and 45° and maximum density 2000kg/m³. Site testing must be carried out on these backfill materials to be verified that the selected materials satisfy these requirements.
 - Bridge deck waterproofing shall be two coats spray applied. This shall be applied to the deck slab between parapet upstand and parapet upstand to a height of 100mm minimum above adjacent deck slab level. The following areas shall also be waterproofed.
Rear of abutment to a minimum 200mm below deck soffit level.
 - All other buried concrete surfaces shall be treated with two coats of epoxy resin waterproofing paint in accordance with the Specification.
 - Reinforcement shall be Grade B500B ribbed bars to BS 4449.
 - All exposed concrete shall be impregnated with a hydrophobic pore liner and anti-graffiti coating.

If Applicable : Ordnance Survey Ireland Licence No. EN 0001220 © Ordnance Survey Ireland and Government of Ireland



No part of this document may be reproduced or transmitted in any form or stored in any retrieval system of any nature without the written permission of Fehily Timoney & Company as copyright holder except as agreed for use on the project for which the document was originally issued. Do not scale. Use figured dimensions only. If in doubt - Ask!

Rev.	Description	App By	Date
A	ISSUE FOR PLANNING APPLICATION	BB	14.10.20

PROJECT	CLIENT		
IMPROVEMENT WORKS TO THE GREAT SOUTHERN GREENWAY	LIMERICK CITY & COUNTY COUNCIL		
	Date 14.10.20	Project number P2152	Scale (@ A1-) As Shown
CATTLE-PASS - TYPICAL DETAILS	Drawn by SK	Drawing Number	Rev
	Checked by TL	P2152-ST00-SD02	A

O:\ACAD\2019\P2152\P2152-ST00-SD02