

Notes

Please refer to Table 1 'Tree Inventory Mungret' when reading this plan.

Do not scale

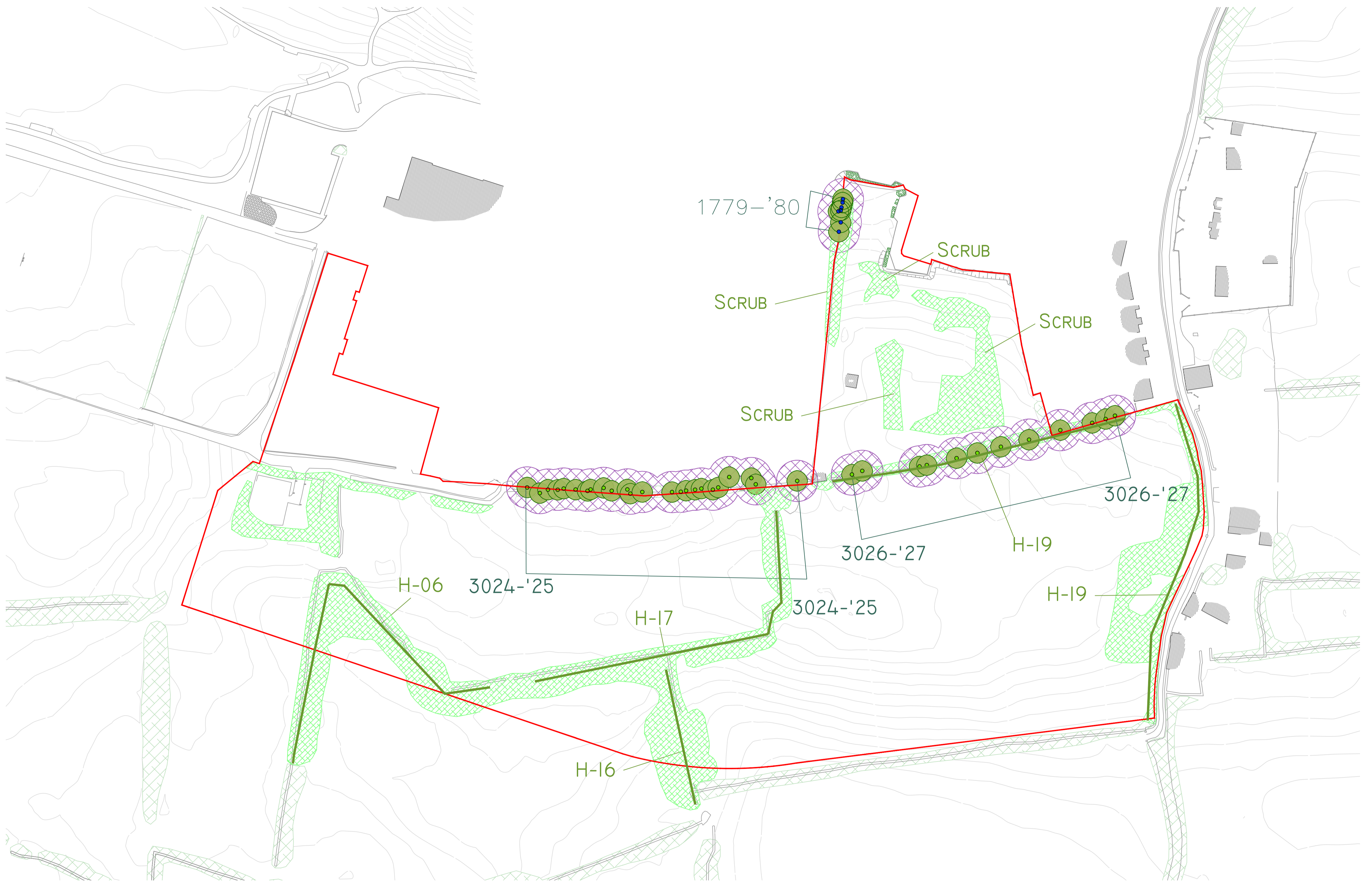

Rev.	Date	Description
D	21.01.21	Trees 1779-80 and scrub added, and scale changed

Legend:

- **Category (A, A1, A2, A3)**
Those of high quality and value: in such a condition as to be able to make a substantial contribution (a minimum of 40 years)
- **Category (C, C1, C2, C3)**
Those of low quality and value: currently in adequate condition to remain until new planting could be established (a minimum of 10 years) or young trees with a stem diameter below 150mm
- **Category (B, B1, B2, B3)**
Those of moderate quality and value: those in such a condition as to make a significant contribution (a minimum of 20 years)
- **Category (U)**
Those in such condition that any existing value would be lost within 10 years and which should, in the current context, be removed for reason of sound agro-cultural management

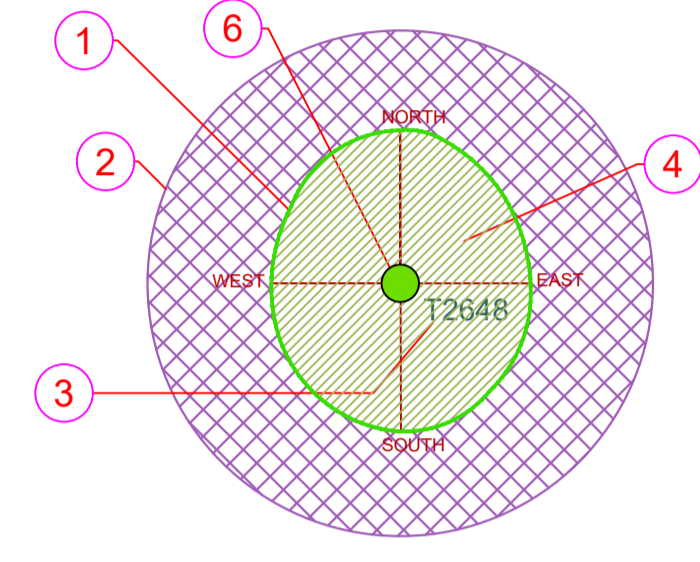

- AGE GROUPINGS**
- Y = YOUNG
 - MA = MIDDLE AGE
 - M = MATURE
 - OM = OVER MATURE
 - V = VETERAN
-

- 1 EXISTING TREE CANOPY BASED ON DIMENSIONS GATHERED ON SITE IN 4 DIRECTIONS, NORTH, SOUTH, EAST AND WEST
- 2 ROOT PROTECTION ZONE BASED ON 12 TIMES THE (DBH) AT CHEST HEIGHT
- 3 TREE TAG NUMBER
- 4 TREE TO BE RETAINED
- 5 TREE TO BE REMOVED
- 6 TREE CATEGORY BASED ON BS:5837 2012 CRITERIA
- 7 DECIDUOUS TREE CANOPY
- 8 EVERGREEN TREE CANOPY

01 TABLES BS 5837-2012

Key

- SITE BOUNDARY
- Foliage
- Hedgerow Reference

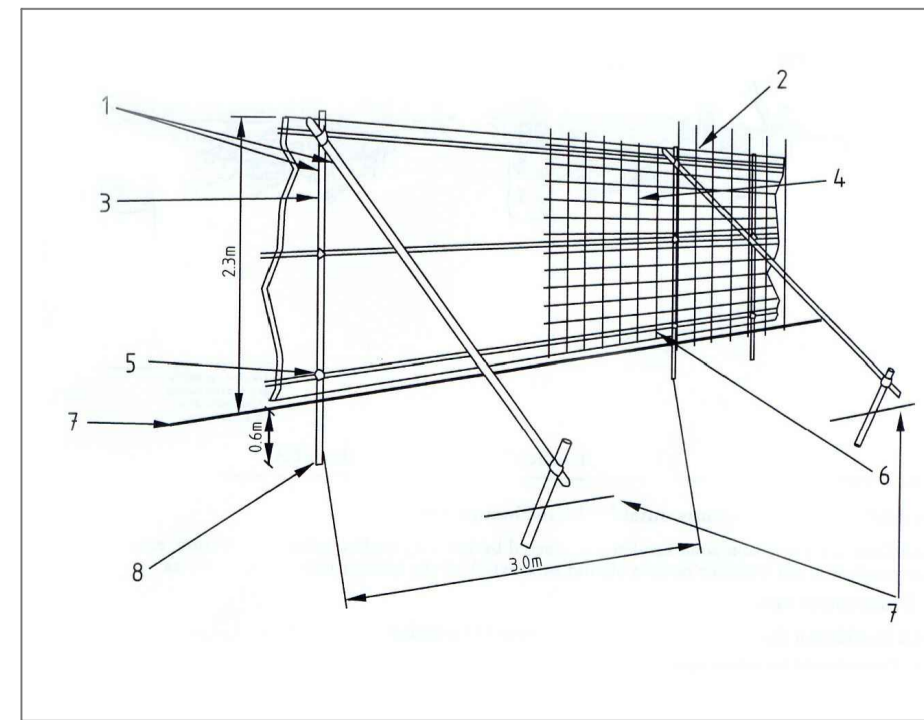

The above displays an example of a suitable protective barrier as recommended by BS. 5837 2012 *Trees in Relation to Construction*

1. Standard scaffold poles
2. Uprights to be driven into the ground
3. Panels secured to uprights with wire ties and where necessary standard scaffold poles
4. Weld mesh wired to the uprights and horizontals
5. Standard clamps
6. Wire twisted and secured on the inside of fencing to avoid easy dismantling
7. Ground level
8. Approx. 0.6m driven into the ground

Client:
Limerick City and County Council
C/o Nicholas de Jong Associates

Project:
Tree survey for the proposed development at Mungret

Drawing Title:
Tree Constraints Plan - Mungret

Drawn By: MG	Checked By: MG	Date: 03/06/18	Scale: 1:1000@A1
Dwg. No. MUNGRET-TS-001-18	CAD File: MUNGRET-TS-001-18.DWG	Issued For: Information	Rev. D

Arbor Care
Unit 1a
Crossagalla Enterprise Centre
Ballysimon Road
Limerick
Ireland

Phone: +353 (0)863082808
Fax: +353 (0)61400321
Email: info@arborcare.ie
Web: www.arborcare.ie

Professional
Consulting, Care Services