

NOTES:

- 1 ALL DIMENSIONS ARE IN MILLIMETRES (mm) UNLESS NOTED OTHERWISE.
- 2 THE MINIMUM DEPTH OF COVER FROM THE FINISHED SURFACE TO THE CROWN OF GRAVITY PIPES WITHOUT PROTECTION SHOULD BE AS FOLLOWS:
 - A. GARDENS AND PATHWAYS WITHOUT ANY POSSIBILITY OF VEHICULAR ACCESS - DEPTH NOT LESS THAN 0.5M (THIS WOULD NORMALLY RELATE TO DRAINS IN PRIVATE PROPERTY, SHALLOW PIPES OF THIS NATURE ARE UNDESIRABLE AND SHOULD BE INSTALLED IN ACCORDANCE WITH THE CURRENT BUILDING REGULATIONS).
 - B. DRIVEWAYS, PARKING AREAS AND YARDS WITH HEIGHT RESTRICTIONS TO PREVENT ENTRY BY VEHICLES WITH A GROSS VEHICLE HEIGHT IN EXCESS OF 7.5 TONNES - DEPTH NOT LESS THAN 0.75m.
 - C. DRIVEWAYS, PARKING AREAS AND NARROW STREETS WITHOUT FOOTWAYS (EG MEWS DEVELOPMENTS) WITH LIMITED ACCESS FOR VEHICLES WITH A GROSS VEHICLE HEIGHT IN EXCESS OF 7.5 TONNES - DEPTH NOT LESS THAN 0.9m.
 - D. DEPTHS OF SEWERS IN GATED ESTATES SHALL BE SIMILAR TO THAT OUTLINED ABOVE.
 - E. AGRICULTURAL LAND AND PUBLIC OPEN SPACE - DEPTH NOT LESS THAN 0.9m.
 - F. OTHER HIGHWAYS AND PARKING AREAS WITH UNRESTRICTED ACCESS TO VEHICLES WITH A GROSS VEHICLE WEIGHT IN EXCESS OF 7.5 TONNES - DEPTH NOT LESS THAN 1.2m.
- 3 CLAUSE 808 MATERIAL IN ACCORDANCE WITH THE NATIONAL ROADS AUTHORITY SPECIFICATION FOR ROAD WORKS IS TO BE USED AS BACKFILL MATERIAL WHERE THE SEWER MAIN IS LOCATED IN ROADS, FOOTPATHS OR WHEN THE NEAREST PART OF THE TRENCH IS WITHIN 1M OF THE PAVED EDGE OF THE ROADWAY, CLAUSE 808 IS TO BE COMPACTED AS PER CLAUSE 802 OF THE NATIONAL ROADS AUTHORITY SPECIFICATION FOR ROAD WORKS.
- 4 SELECTED EXCAVATED MATERIAL MAY BE USED IN GREEN-FIELD AREAS ABOVE GRANULAR PIPE SURROUND MATERIAL SUBJECT TO THE APPROVAL OF IRISH WATER.
- 5 PIPE BEDDING SHALL COMPLY WITH WS 4-08-02 AND ON 4-08-01 GRANULAR MATERIAL SHALL BE 14mm TO 5MM GRADED AGGREGATE OR 10MM SINGLE SIZED AGGREGATE IS EN 13242. CONCRETE BED, HAUNCH & SURROUND, WHERE REQUIRED, SHALL BE TO STD-WW-08.
- 6 IN SOFT GROUND CONDITIONS (CBR < 5) THE MATERIAL SHOULD BE EXCAVATED AND DISPOSED OF IN ACCORDANCE WITH THE WASTE MANAGEMENT ACT AND CLAUSE 808 MATERIAL IN ACCORDANCE WITH THE NATIONAL ROADS AUTHORITY SPECIFICATION FOR ROAD WORKS SHALL REPLACE THE EXCAVATED MATERIAL WRAPPED IN GEO-TEXTILE WRAPPING, ALTERNATIVELY, SPECIAL PIPE SUPPORT ARRANGEMENTS, INCLUDING PILING ETC. MAY BE REQUIRED WHERE THE DEPTH OF SOFT MATERIAL IS EXCESSIVE. SUCH ARRANGEMENTS SHALL BE SUBJECT TO ASSESSMENT BY IRISH WATER BEFORE ADVANCING WITH THE WORK.
- 7 IN GREEN FIELD AREAS, TYPE B BACKFILL (SELECTED EXCAVATED MATERIAL) WILL BE ALLOWED ABOVE THE SIDE HAUNCH GRANULAR MATERIAL IN THE CASE OF RIGID PIPES. A GRANULAR SURROUND OF A MINIMUM DEPTH OF 150mm ABOVE THE CROWN OF THE PIPE IS REQUIRED FOR FLEXIBLE PIPES, AND TYPE B MATERIAL MAY BE USED AS BACKFILL ABOVE THIS. ALL RISING MAINS IN GREENFIELD AREAS SHALL HAVE A MINIMUM COVER OF 300mm OF GRANULAR MATERIAL ABOVE THE EXTERNAL CROWN OF THE PIPE.
- 8 PIPES SHALL NOT BE SUPPORTED ON STONES, ROCKS OR ANY HARD OBJECTS AT ANY POINT ALONG THE TRENCH, ROCK SHALL BE EXCAVATED TO A DEPTH OF 150mm BELOW THE ACTUAL DEPTH OF THE TRENCH WITH THE VOID FILLED WITH CLAUSE 808 MATERIAL IN ACCORDANCE WITH THE NATIONAL ROADS AUTHORITY SPECIFICATION FOR ROAD WORKS. THE GRANULAR MATERIAL SHALL BE LAID ABOVE THIS VOID BACKFILL MATERIAL.
- 9 NON DEGRADABLE MARKER TAPE SHOULD BE INSTALLED AT TOP OF PIPE BEDDING LAYER. IN THE CASE OF NON-METAL PIPE MATERIAL, THE MARKER TAPE SHOULD INCORPORATE A TRACE WIRE WHICH IS LINKED TO FITTINGS AND TERMINATED AT THE WASTE WATER PUMPING STATION AND THE DISCHARGE MANHOLE.
- 10 TRENCH WIDTHS FOR PIPE SIZES <80mm MAY BE <500mm, SUBJECT TO CONSIDERATION BEING GIVEN TO THE TRENCH DEPTH, HEALTH & SAFETY & CONSTRUCTION ACCESS REQUIREMENTS.

PIPE DIAMETER 'A' (mm)	DEPTH OF BEDDING 'C' (mm)
< 80 RISING MAIN	< SEE NOTE 10.
< 100	100
150 - 450	200

PIPE DIAMETER 'A' (mm)	TRENCH WIDTH 'B' (mm)
< 80 RISING MAIN	< SEE NOTE 10.
100	500
150	600
200	600
250	750
300	750
350	750
400	900
450	900

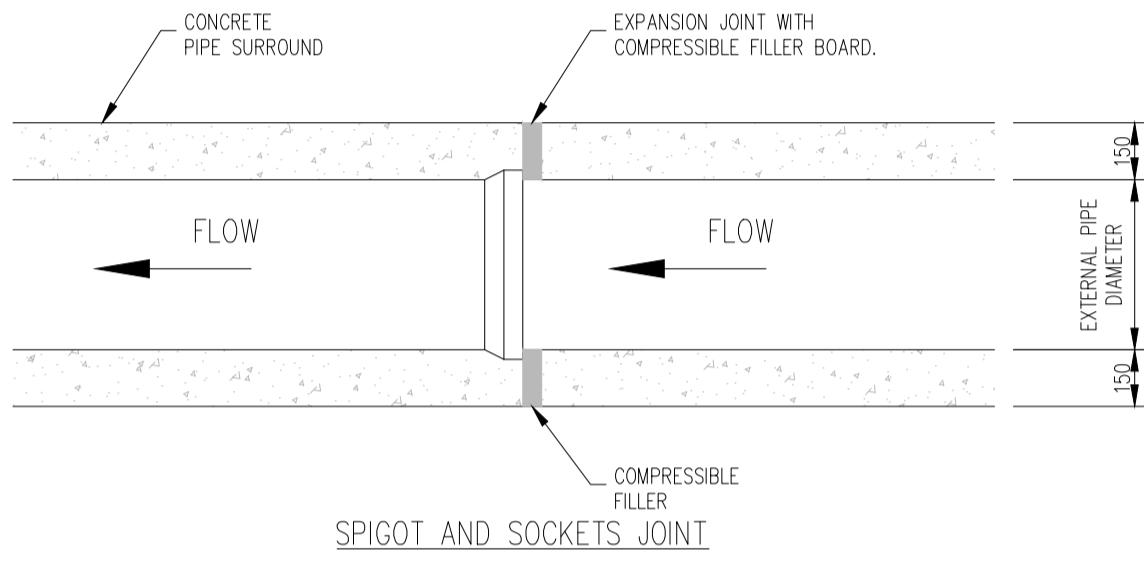
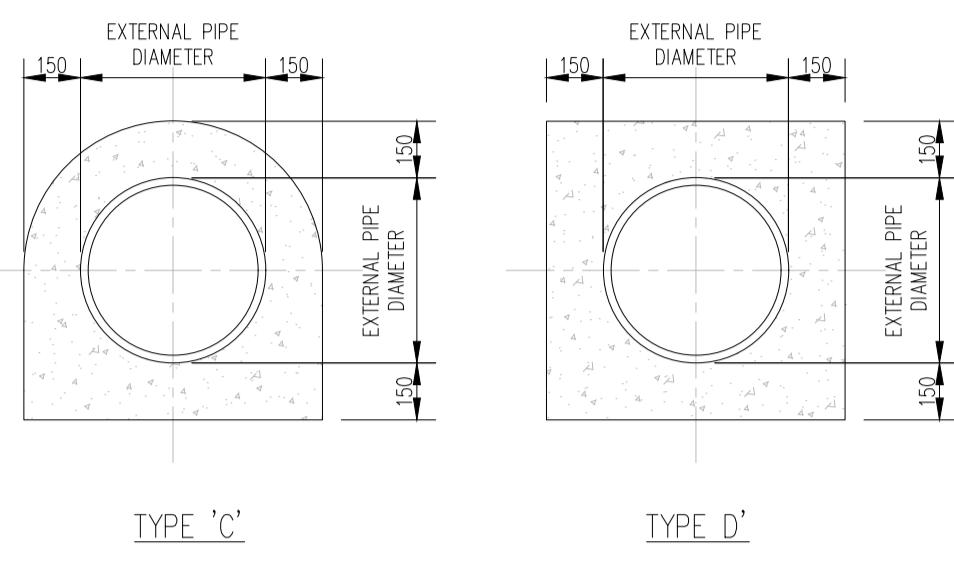
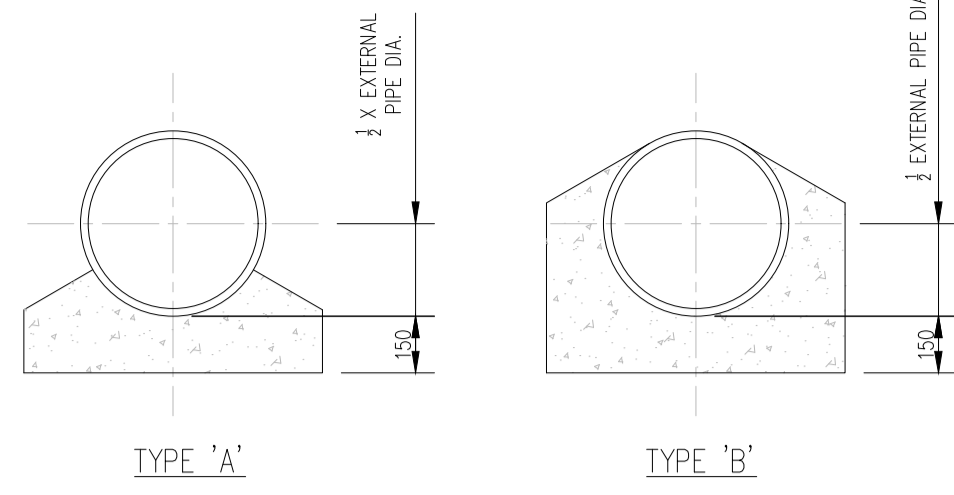

CONCRETE BED, HAUNCH AND SURROUND TO WASTEWATER PIPES. (STD-WW-08) SCALE 1:20

NOTES:

1. ALL DIMENSIONS ARE IN MILLIMETERS (mm) UNLESS NOTED OTHERWISE.
2. CONCRETE PIPELINE BEDS AND HAUNCHES MAY BE REQUIRED TO ADDRESS MINIMUM COVER SITUATIONS, AND SHALL BE SUBJECT TO SUBMISSION AND ASSESSMENT BY IRISH WATER BEFORE ADVANCING WITH THE WORKS.
3. CONCRETE PIPE BEDS AND HAUNCHES SHALL HAVE A MINIMUM THICKNESS OF 150MM WITH AN ABSOLUTE MINIMUM DEPTH OF COVER ABOVE THE EXTERNAL CROWN OF THE PIPE OF 750MM CONCRETE TO BE IN ACCORDANCE WITH IS EN 206 AND TO BE CLASSED C16/20.
4. THE HAUNCHES AND SURROUNDINGS TO BE FORMED USING FORM WORK TO PROVIDE A ROUGH CAST FINISH.
5. EXPANSION JOINTS IN THE CONCRETE SHALL BE PROVIDED AT ALL PIPE JOINTS TO ALLOW FOR PIPE FLEXIBILITY, COMPRESSIBILITY FILLER BOARD TO BE IN ACCORDANCE WITH BS EN 622-1 AND BS EN 622-4, AND TO BE 18mm THICK.
6. POLYETHYLENE PIPES SHALL BE WRAPPED IN PLASTIC SHEETING HAVING A COMPLETION WITH ACCORDANCE WITH BS6076 BEFORE BEING CAST INTO CONCRETE.
7. BITUMINOUS MATERIAL SHALL NOT BE PUT IN CONTACT WITH PE OR PVC PIPES.

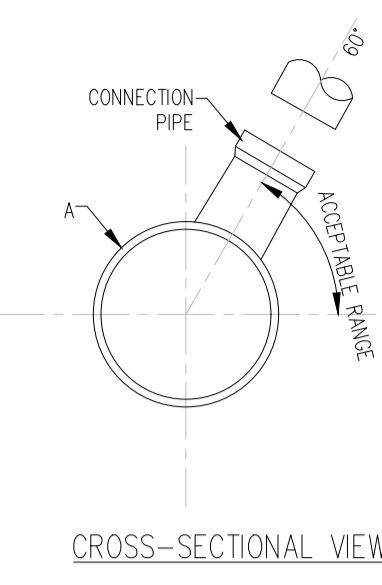

CROSS-SECTIONAL VIEW OF SEWER

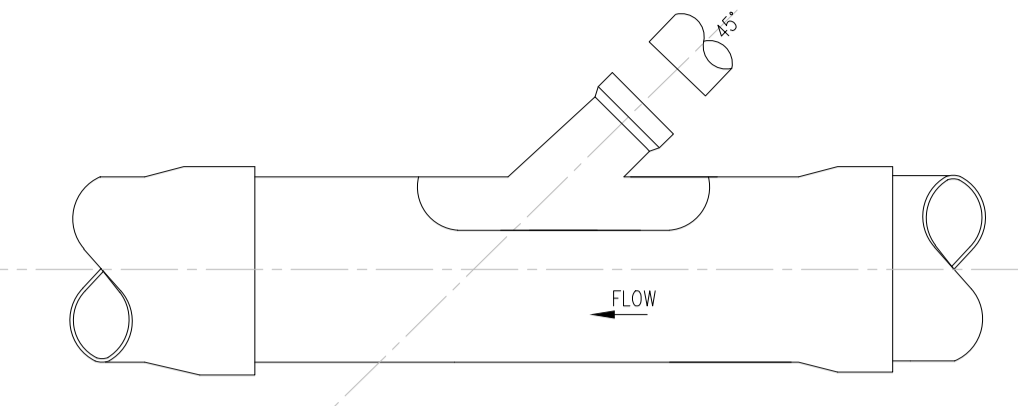

VIEW IN DIRECTION OF ARROW A

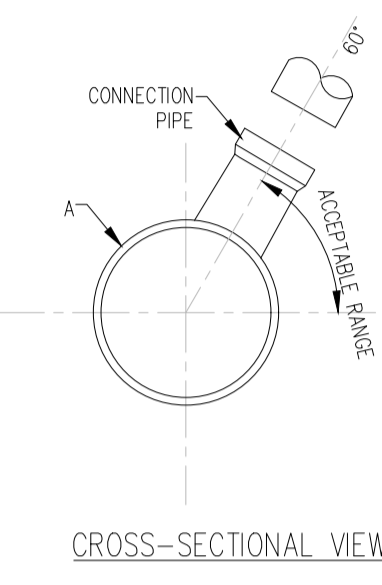

CROSS-SECTIONAL VIEW OF SEWER

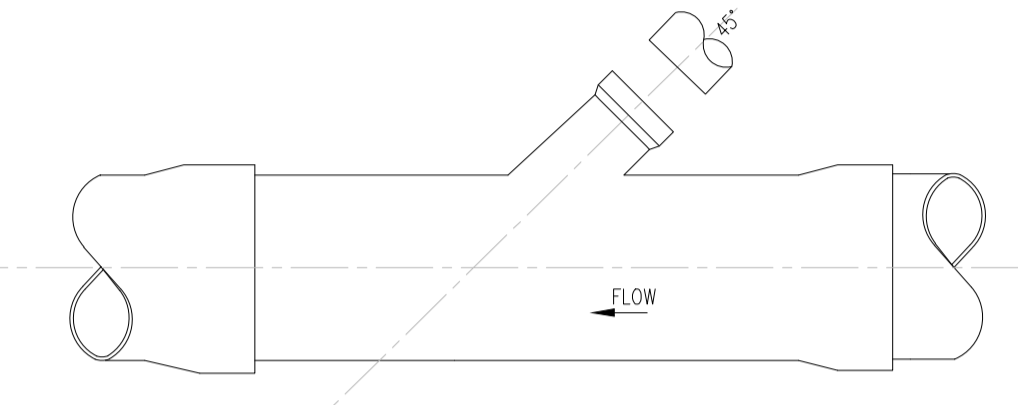

VIEW IN DIRECTION OF ARROW A

APPROVED 45° SADDLE CONNECTION (STD-WW-04) SCALE 1:20

NOTES:

1. ALL DIMENSIONS ARE IN MILLIMETERS (mm) UNLESS NOTED OTHERWISE.
2. AS FAR AS PRACTICABLE, JUNCTION AND SERVICE CONNECTION SHALL BE BUILT IN FOR ALL PLANNED SITUATIONS WHEN THE SEWER IS BEING CONSTRUCTED. WHETHER IT IS NECESSARY TO MAKE A POST-CONSTRUCTION CONNECTION THE DEVELOPER SHALL BRING THE SEWER TO THE INSPECTION CHAMBER, INSTALL THE INSPECTION CHAMBER AND SEAL THE UPSTREAM END UNTIL THE CONNECTION IS REQUIRED.
3. THE VERTICAL ANGLE BETWEEN THE SERVICE CONNECTING PIPE AND THE HORIZONTAL SHALL BE GREATER THAN 0° AND NOT MORE THAN 60°.
4. WHERE THE CONNECTION IS BEING MADE TO A SEWER WITH A NORMAL INTERNAL DIAMETER OF 300mm DIAMETER OF LESS, CONNECTIONS SHALL BE MADE USING 45° ANGLE JUNCTION.
5. WHERE THE CONNECTION IS BEING MADE TO A SEWER WITH NORMAL INTERNAL DIAMETER GREATER THAN 300mm:
 - A) IF THE DIAMETER OF THE CONNECTION PIPE IS GREATER THAN HALF THE DIAMETER OF THE SEWER, AN ACCESS MANHOLE SHALL BE CONSTRUCTED TO FORM THE CONNECTION POINT; OR
 - B) IF THE DIAMETER OF THE CONNECTION PIPE IS LESS THAN OR EQUAL TO HALF DIAMETER OF THE SEWER, THAN THE CONNECTION SHALL BE MADE USING A PREFORMED SADDLE FITTING WITH A SLOW BEND BETWEEN THE SADDLE AND THE CONNECTION SEWER/DRAIN.
6. CONNECTIONS MADE WITH THE SADDLE FITTINGS SHALL BE MADE BY CUTTING AND SAFELY REMOVING A CORE FROM THE PIPE AND JOINING THE SADDLE FITTING TO THE PIPE IN ACCORDANCE WITH THE MANUFACTURER'S INSTRUCTIONS TO ENSURE A WATER TIGHT JOINT. THE CONNECTING PIPE SHALL NOT PROTRUDE INTO THE SEWERS.

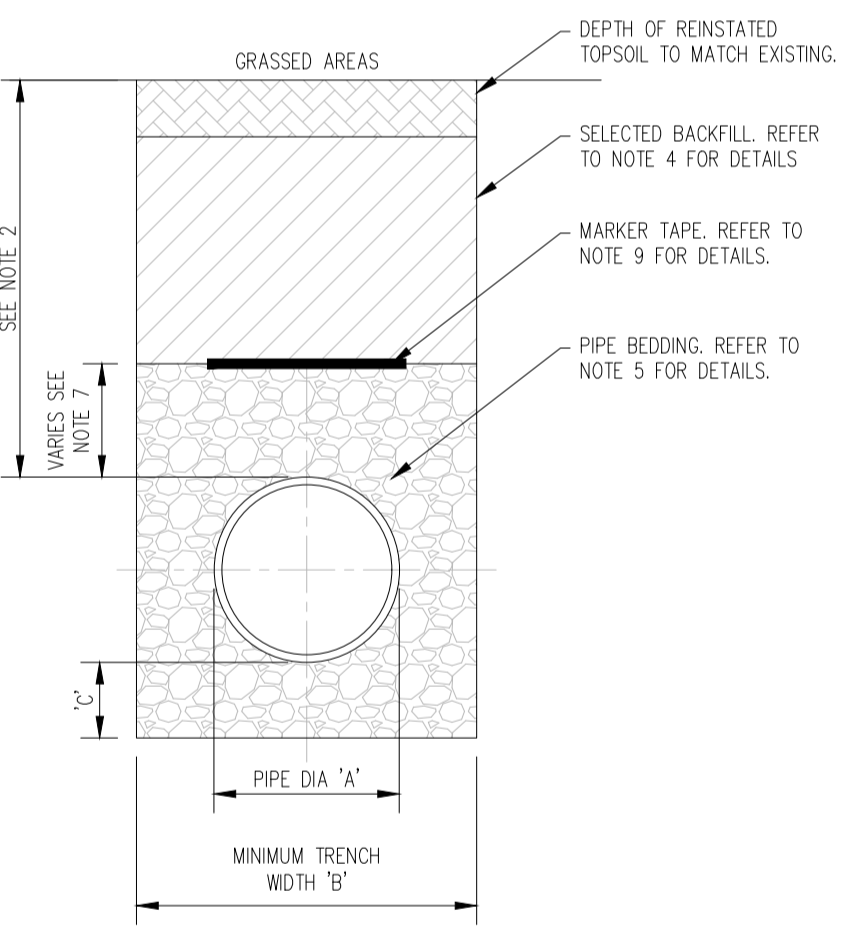

CROSS SECTION IN GRASSED AREAS

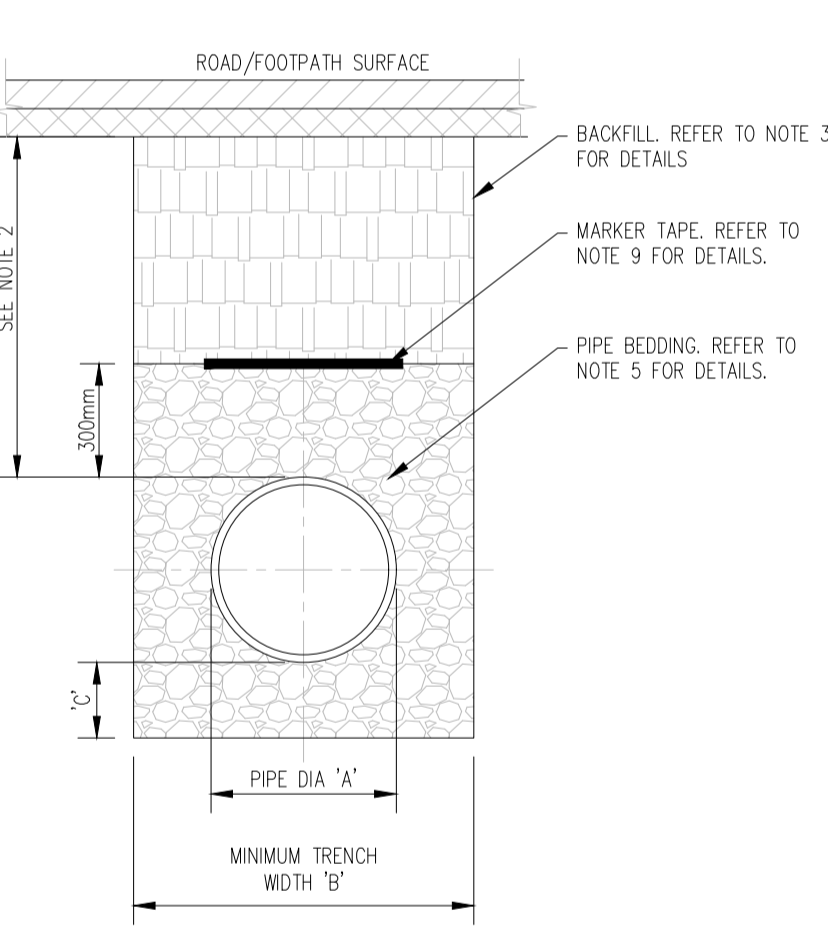

CROSS SECTION IN ROADS

TRENCH BACKFILL AND BEDDING (STD - WW - 07) SCALE 1:20

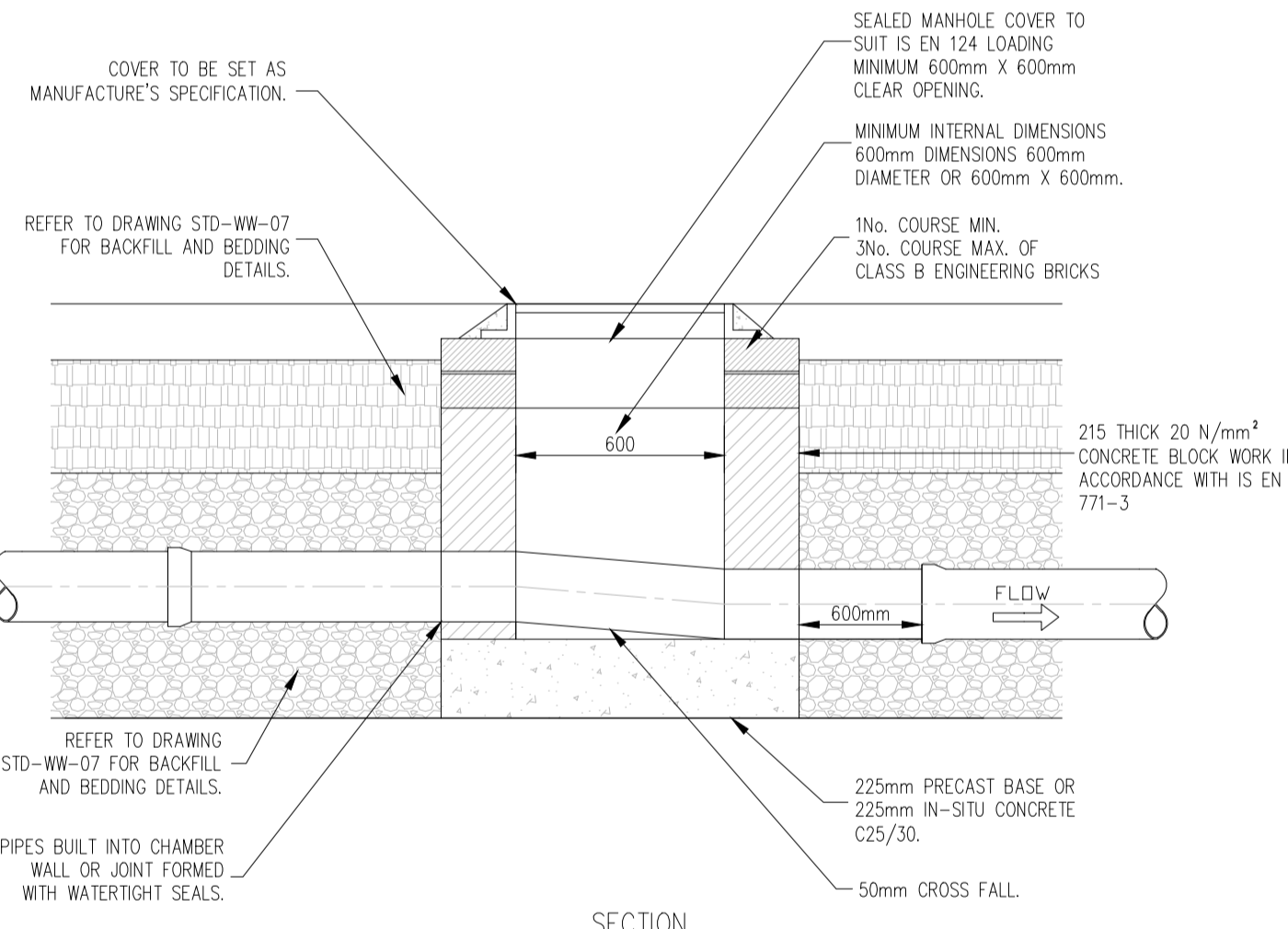

SECTION

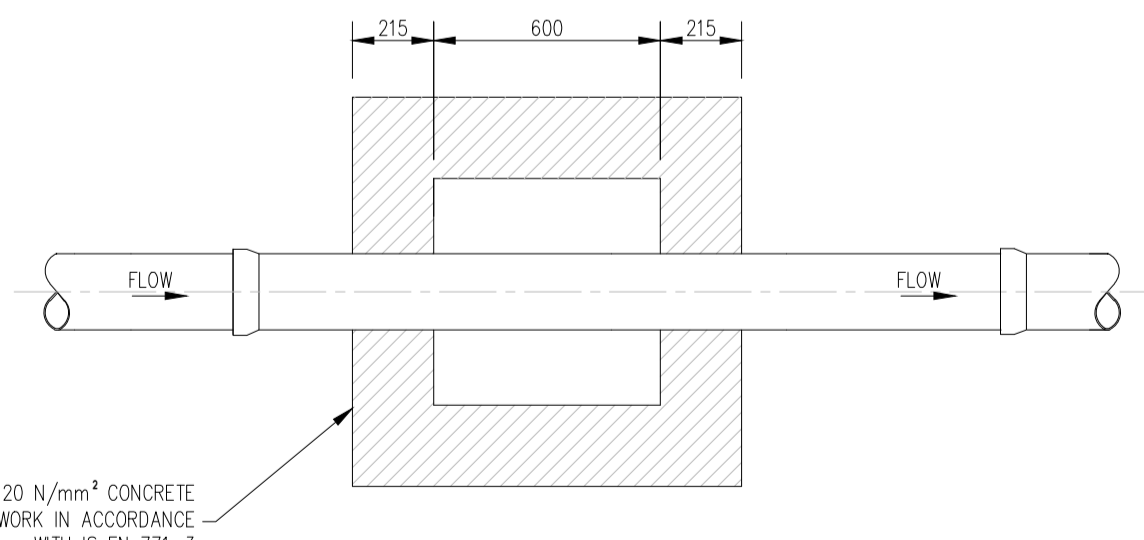

PLAN INSPECTION CHAMBER (BLOCKWORK CONSTRUCTION)

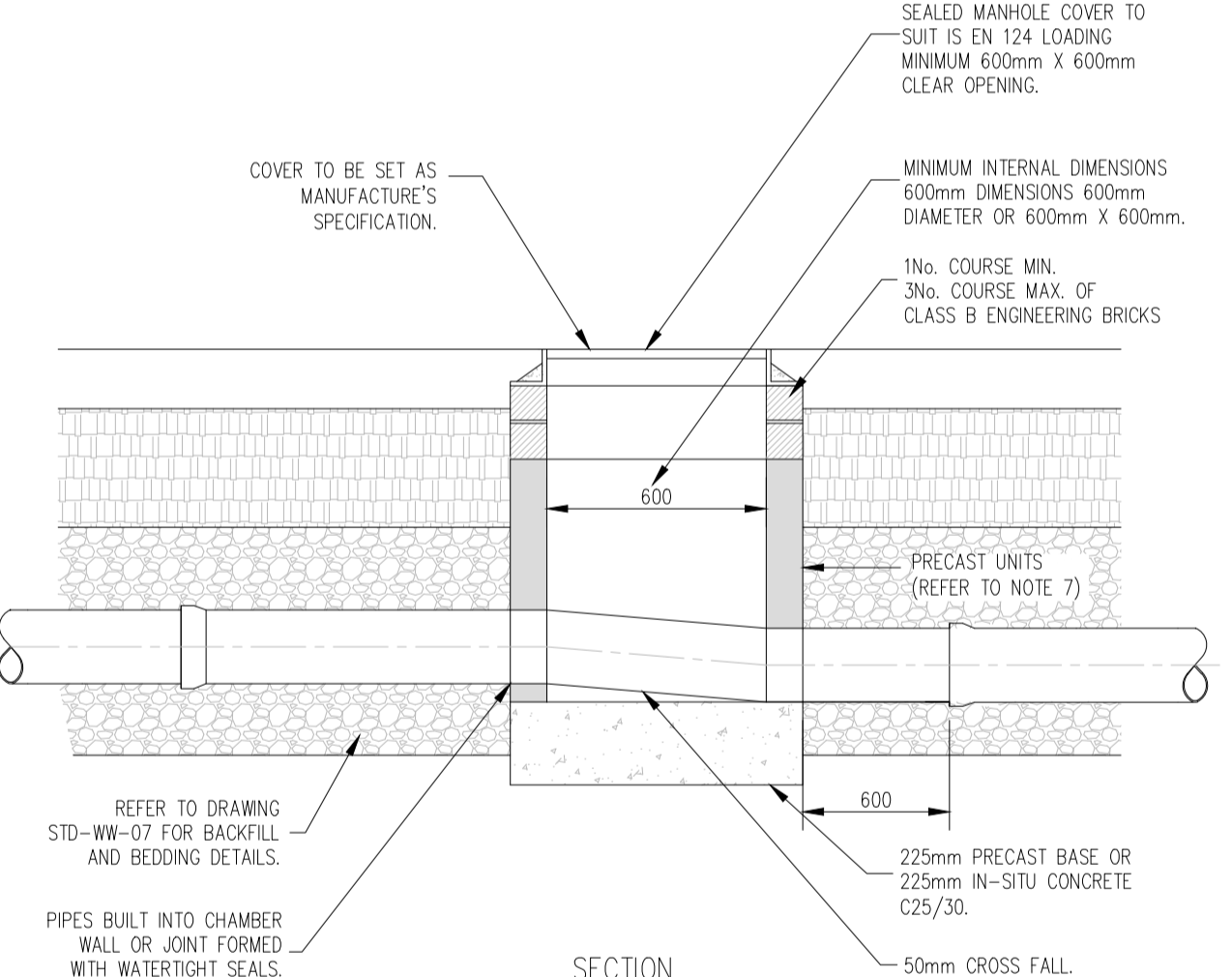

SECTION

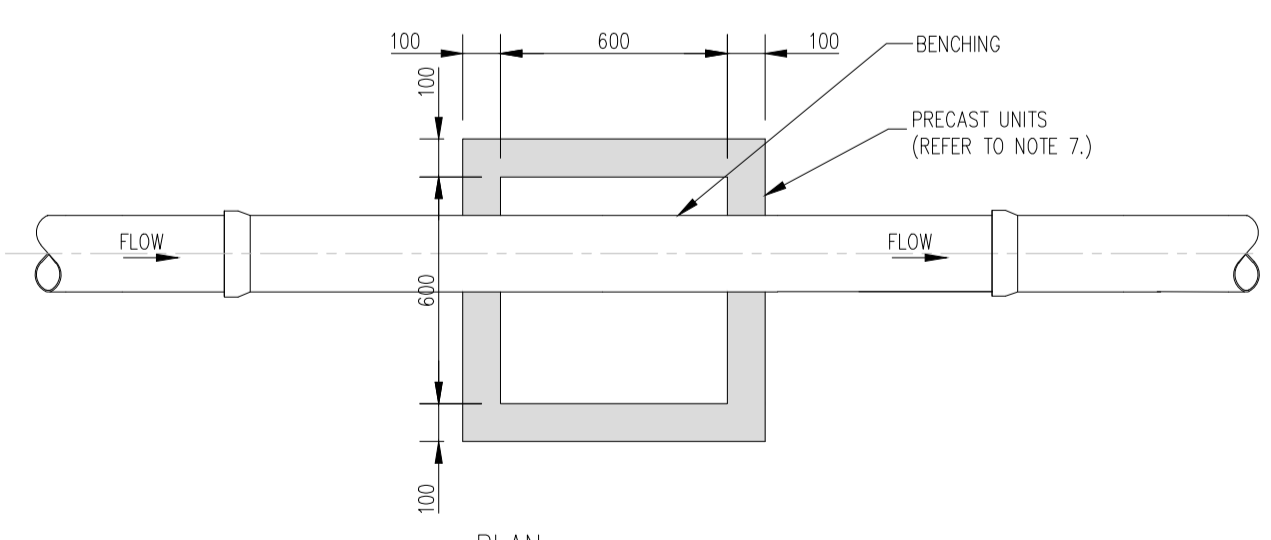

PLAN INSPECTION CHAMBER (PRECAST CONCRETE CONSTRUCTION)

NOTES:

1. ALL DIMENSIONS ARE IN MILLIMETERS (mm) UNLESS NOTED OTHERWISE.
2. AN INSPECTION CHAMBER SHOULD BE LOCATED AT OR WITHIN 1m OF THE PROPERTY BOUNDARY AT THE UPSTREAM END OF EACH SERVICE CONNECTION ON THE PRIVATE SIDE OF THE CURTLAGE, IF PRACTICABLE.
3. ANY PIPE AND ASSOCIATED ACCESS UPSTREAM OF THE POINT OF CONNECTION TO A PUBLIC SEWER IS A PRIVATE DRAIN AND SHOULD BE CONSTRUCTED IN ACCORDANCE WITH THE BUILDING REGULATIONS.
4. ACCESS POINTS SHOULD BE LOCATED SO THAT THEY ARE ACCESSIBLE AND APPARENT TO THE MAINTAINER AT ALL TIMES FOR USE. THEY SHOULD AVOID REAR GARDENS OR ENCLOSED LOCATIONS AND THEY SHOULD NEVER BE OVERLAIN WITH SURFACE DRESSING, TOPSOIL, ETC.
5. COVERS AND FRAMES SHALL BE SUITABLE FOR ROAD AND TRAFFIC CONDITIONS SUBJECT TO APPROVAL FROM IRISH WATER.
6. 200mm ALL AROUND, 100mm DEEP CONCRETE PLINTH WITH PROTECTIVE STAINLESS STEEL METAL BAND AROUND COVERS IN GREEN AREAS.
7. PROPERLY PREFABRICATED CHAMBER UNITS MAY ALSO BE USED SUBJECT TO APPROVAL FROM IRISH WATER.
8. CONCRETE CHAMBER SHALL BE SURROUNDED BY A MINIMUM OF 150mm COMPACTED CLAUSE 804 OR CLAUSE 808 MATERIAL AS PER STD-WW-07.

NOTES:

1. For setting out refer to Architect's drawings.
2. This drawing to be read in conjunction with all other Architectural and Engineering drawings and all other relevant drawings and Specifications.
3. DO NOT SCALE THIS DRAWING. Use figured dimensions only.
4. No part of this document may be reproduced or transmitted in any form or stored in any retrieval system of any nature without the written permission as copyright holder except as agreed for use on the project for which the document was originally issued.
5. Ordnance Survey Ireland Licence Number EN 0074012

Rev. No.	Date	REVISION NOTE

Client	Project	Title
Limerick City & County Council	Church Glen Housing Ballylanders, Co.Limerick	Drainage Details 3

Client	Project	Title
Limerick City & County Council	Church Glen Housing Ballylanders, Co.Limerick	Drainage Details 3

Client	Project	Title
Limerick City & County Council	Church Glen Housing Ballylanders, Co.Limerick	Drainage Details 3

Cronin Sutton Cotter
 45 O'Connell Street, Limerick, Co. Limerick
 T: +353 (0) 61 594988
 E: info@csconsulting.ie
 W: www.csconsulting.ie

Quality Environment Energy Health & Safety
 I.S. EN ISO 9001:2008
 I.S. EN ISO 14001:2004
 I.S. EN ISO 50001:2011
 OHSAS 18001:2007